

- NOTE
1. MATERIALS: HOUSING PBT UL94V-0.
CONTACT PHOSPHOR BRONZE .
 2. PLATING:
G: RoHS (Tin 100u" over Ni 50u")
2: Gold Flash 1u"
 3. FLASH, AREA B: NA, OTHERS 0.20mm MAX.
 4. CAMBER: 0.05mm/cm MAX, DEFORMATION: NA, WARPAGE: 0.05mm/cm MAX, TWIST: NA.
 5. PART NO

GS026 - 01 1 X-3

BATTERY DIM,
D=19.8, T=3.2(2032)

G: RoHS (Tin 100u"
over Ni 50u")
2: Gold Flash 1u"

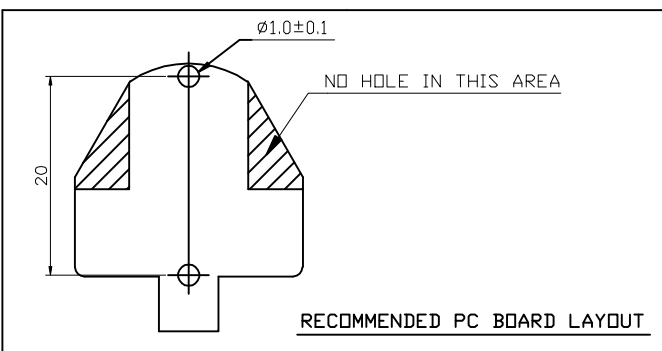

UNIT: mm

A3 RELEASE		25/04/15'	Material: ---	Customer drawing	 Global Shine Technology Co., Ltd. TEL: 8531-7318 FAX: 8531-7319
A2 RELEASE		17/10/14'	Finish: ---		
A1 RELEASE		07/16/08'	General Tolerances: Angle: ±3°	Dim: 0.0 ±0.25 0.00 ±0.20 0.000 ±0.08	Date: 25/04/15' Sheet 1 of 1
A REVISE		04/12/02'	Drawn by	Chk'd by	DWG. NO. GS026-XXXX-3 REV. A3
REV Revision Record		Date	Appr'd by	Scale	Title: BATTERY HOLDER ASS'Y
Revise Only In Cad System			2 : 1		