

PART NO	ØA	B
GS025-01**	22.8	27.8
GS025-02**	25.4	29.0

- NOTES
1. MATERIALS:
HOUSING-PBT 30%GF UL94V-0.
CONTACT-PHOSPHOR BRONZE, C5191R-H T=0.5mm.
 2. FLASH: 0.25mm MAX.
 3. CAMBER: 0.13mm MAX. DEFORMATION: NA.
WARP: 0.13mm MAX. TWIST: NA.
 4. P/N:

GS025-XX X X
 BATTERY DIM. _____
 01: D=19.8, T=3.2
 02: D=22.8, T=3.2
 PLATING:
 1.TIN 100u" MIN OVER NI 50u" MIN.
 2.Ni 80u" MIN.
 COLOR:
 1.BLACK

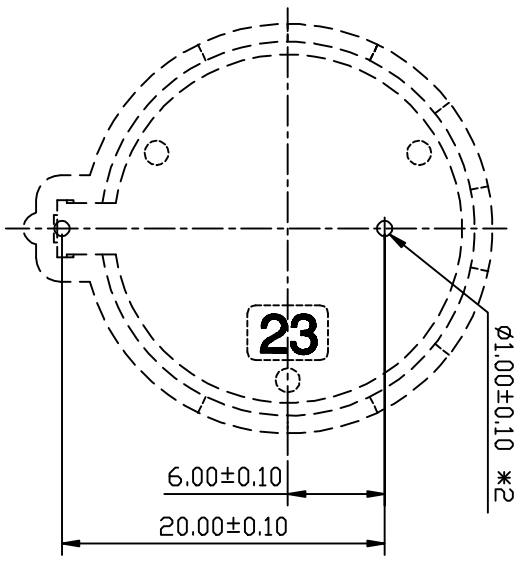

RECOMMEND PCB LAYOUT
COMPONENT SIDE

ENGINEERING DRAWING		UNIT: mm		Global Shine Technology Co., Ltd. TEL:8591-7918 FAX:8591-7919	
C	RC-2015-036	20/05/015	General Tolerances: H/Upper +Z	Dim: 0.0	Date: 20/05/015
B	RC-2015-026	04/25/015	±0.20	Sheet 1 OF 1	
A	正式版發行	06/30/009	0.00 ±0.13 0.00 ±0.05	DWG. NO GS025-XX X X	REV: C
REV	Revision Record	Date	CHK'd by	Drawn by	Appr'd by
Revise Only Dn Cad System					
			Scale 2 : 1	Title: BATTERY HOLDER ASS'Y	